

VT6EDCR - 062 - 035 - 017 - 1 R 00 - A 1 - P - 00 - *

Series

Rear cap end for mounting
SAE "A" auxiliary pump
coupling adaptor SAE "A" -9 teeth

P1

P2

P3

Cam ring for "P1"

Volumetric displacement cm³/rev (in³/rev)

042 = 132.3 (8.07)	062 = 196.7 (12.00)
045 = 142.4 (8.69)	066 = 213.3 (13.02)
050 = 158.5 (9.67)	072 = 227.1 (13.86)
052 = 164.8 (10.06)	085 = 269.8 (16.46)
057 = 180.7 (11.02)	

Cam ring for "P2"

Volumetric displacement cm³/rev (in³/rev)

* 014/B14 = 47.6 (2.90)	035/B35 = 111.0 (6.77)
017/B17 = 58.2 (3.55)	038/B38 = 120.3 (7.34)
020/B20 = 66.0 (4.03)	042/B42 = 136.0 (8.30)
024/B24 = 79.5 (4.85)	045/B45 = 145.7 (8.89)
028/B28 = 89.7 (5.47)	050/B50 = 158.0 (9.64)
031/B31 = 98.3 (6.00)	061/B61 = 190.5 (11.62)

*0 - Uni - directional 'B' - Bi - directional

Cam ring for "P3"

Volumetric displacement cm³/rev (in³/rev)

*003/B03 = 10.8 (0.66)	015/B15 = 50.5 (3.08)
005/B05 = 17.2 (1.05)	017/B17 = 58.3 (3.56)
006/B06 = 21.3 (1.30)	020/B20 = 63.8 (3.89)
008/B08 = 26.4 (1.61)	022/B22 = 70.3 (4.29)
010/B10 = 34.1 (2.08)	025/B25 = 79.3 (4.84)
012/B12 = 37.1 (2.26)	028/B28 = 88.8 (5.42)
014/B14 = 46.0 (2.81)	031/B31 = 100.0 (6.10)

*0 - Uni - directional 'B' - Bi - directional

Modifications

Mounting w/connection variables

00 = P3 = 1" SAE
01 = P3 = 3/4" SAE

Mounting (pump)

P= Pedestal mounting
F= Face mounting

Seal class

1 - S1 (for mineral oil)
4 - S4 (for fire resistant fluids)
5 - S5 (for mineral oil and fire resistant fluids)

Design letter

Porting combination (see page DI-1-13)

00 = Standard

Direction of rotation (view on shaft end)

R - Clockwise
L - Counter - clockwise

Type of Shaft

1 - Keyed (G45N-ISO 3019-2)
3 - Splined (SAE D & E)

OPERATING CHARACTERISTICS - TYPICAL (24 cST) (Input power p (KW) for one cartridge only)

Pressure port	Series	Volumetric Displacement Vp		Flow q & n = 1500 rpm						Input power p & n = 1500 rpm					
		in ³ /rev	cm ³ /rev	p = 0 bar (0 psi)		p = 140 bar (2000 psi)		p = 240 bar (3500 psi)		p = 7 bar (100 psi)		p = 140 bar (2000 psi)		p = 240 bar (3500 psi)	
				gpm	lpm	gpm	lpm	gpm	lpm	hp	kw	hp	kw	hp	kw
P1	042	8.07	132.3	52.50	198.5	49.87	188.5	47.96	181.3	6.97	5.2	66.25	49.4	110.77	82.6
	045	8.70	142.4	56.51	213.6	53.86	203.6	51.98	196.5	7.24	5.4	70.94	52.9	118.95	88.7
	050	9.67	158.5	62.88	237.7	60.24	227.7	58.36	220.6	7.64	5.7	78.45	58.5	131.82	98.3
	052	10.00	164.8	65.40	247.2	62.75	237.2	60.87	230.1	7.78	5.8	81.53	60.8	136.92	102.1
	057	11.02	180.7	71.71	271.1	69.07	261.1	67.19	254.0	8.18	6.1	89.04	66.4	143.35	106.9
	062	12.00	196.7	78.04	295.0	75.40	285.0	73.52	277.9	8.58	6.4	96.42	71.9	162.67	121.3
	066	13.00	213.3	84.63	319.9	81.98	309.9	80.11	302.8	8.98	6.7	104.20	77.7	175.94	131.2
	072	13.86	227.1	90.11	340.6	87.46	330.6	85.58	323.5	9.25	6.9	110.77	82.6	187.07	139.5
	085 ¹⁾	16.40	269.8	107.00	404.7	105.21 ²⁾	397.7 ²⁾	--	--	9.78	7.3	87.56 ²⁾	65.3 ²⁾	--	--
P2	014	2.90	47.6	18.88	71.4	16.42	62.1	14.78	55.9	3.08	2.3	24.81	18.5	41.03	30.6
	017	3.55	58.2	23.09	87.3	20.63	78.0	18.99	71.8	3.35	2.5	29.75	22.2	49.60	37.0
	020	4.00	66.0	26.19	99.0	23.73	89.7	22.08	83.5	3.75	2.8	33.39	24.9	55.92	41.7
	024	4.80	79.5	31.56	119.3	29.10	110.0	27.46	103.8	4.02	3.0	39.69	29.6	66.78	49.8
	028	5.50	89.7	35.58	134.5	33.12	125.2	31.48	119.0	4.29	3.2	44.52	33.2	74.96	55.9
	031	6.00	98.3	39.00	147.5	36.53	138.1	34.89	131.9	4.42	3.3	48.54	36.2	81.80	61.0
	035	6.80	111.0	44.04	166.5	41.58	157.2	39.94	151.0	4.69	3.5	54.58	40.7	92.13	68.7
	038	7.30	120.3	47.72	180.4	45.26	171.1	43.62	164.9	4.96	3.7	58.87	43.9	99.64	74.3
	042	8.30	136.0	53.96	204.0	51.50	194.7	49.86	188.5	5.36	4.0	66.25	49.4	112.24	83.7
	045	8.89	145.7	57.80	218.5	55.34	209.2	53.70	203.0	5.50	4.1	70.81	52.8	120.02	89.5
	050	9.64	158.0	62.69	237.0	60.23	227.7	59.25 ³⁾	224.0 ³⁾	5.90	4.4	76.44	57.0	113.98 ³⁾	85.0 ³⁾
P3	061	11.62	190.5	76.25	285.7	73.54 ⁴⁾	278.0 ⁴⁾	--	--	6.16	4.6	81.26 ⁴⁾	60.6 ⁴⁾	--	--
	003	0.66	10.8	4.29	16.2	2.96	11.2	2.04	7.7	1.74	1.3	7.11	5.3	11.22	8.4
	005	1.05	17.2	6.83	25.8	5.50	20.8	4.57	17.3	1.88	1.4	10.06	7.5	16.36	12.2
	006	1.30	21.3	8.44	31.9	7.11	26.9	6.19	23.4	2.01	1.5	11.94	8.9	19.71	14.7
	008	1.61	26.4	10.48	39.6	9.15	34.6	8.22	31.1	2.15	1.6	14.35	10.7	22.93	17.7
	010	2.08	34.1	13.52	51.1	12.19	46.1	11.26	42.6	2.28	1.7	18.64	13.4	29.90	22.3
	012	2.26	37.1	14.71	55.6	13.36	50.6	12.46	47.1	2.28	1.7	19.31	14.4	32.32	24.1
	014	2.81	46.0	18.25	69.0	16.93	64.0	16.00	60.5	2.55	1.9	23.60	17.6	39.56	29.5
	015	3.08	50.5	20.00	75.6	18.73	73.2	19.02	67.5	2.68	2.0	25.61	19.1	42.91	32.0
	017	3.56	58.3	23.12	87.4	21.79	82.4	20.87	78.9	2.82	2.1	29.37	21.9	49.48	36.9
	020	3.89	63.8	25.32	95.7	23.99	90.7	23.07	87.2	2.95	2.2	31.92	23.8	53.91	40.2
	022	4.29	70.3	27.88	105.4	26.56	100.4	25.63	96.9	3.08	2.3	35.00	26.1	59.14	44.1
	025	4.84	79.3	31.46	118.9	30.13	113.9	29.21	110.4	3.35	2.5	39.16	29.2	66.38	49.5
	028	5.42	88.8	35.24	133.2	33.92	128.2	33.28 ⁴⁾	125.8 ⁴⁾	3.75	2.8	43.85	32.7	65.04 ⁴⁾	48.5 ⁴⁾
	031	6.10	100.0	39.68	150.0	38.35	145.0	37.72 ⁴⁾	142.6 ⁴⁾	3.75	2.8	48.95	36.5	72.95 ⁴⁾	54.4 ⁴⁾

1) 085 = 2000 RPM max.

2) 085 = 75 bar (1100 psi) cont.

085 = 90 bar (1300 psi) max. int.

3) 028-031-050=210 bar (3000 psi) max.

4) 061 = 120 bar(1740 psi) max. int, 061 = 80 bar (1160 psi) cont.



INTERNAL LEAKAGE (TYPICAL)

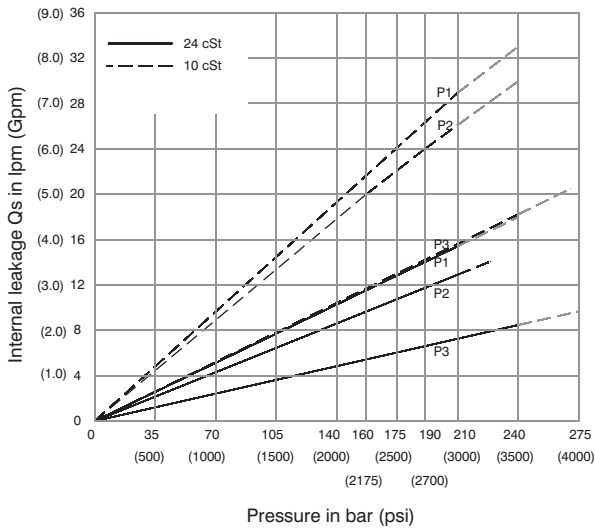

Total leakage is the sum of each section loss at its operating conditions.

NOISE LEVEL (TYPICAL)

VT6EDCR- 062-035-017

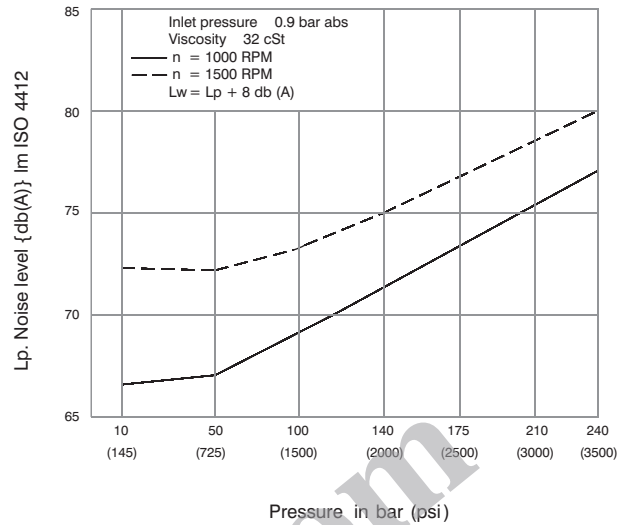

Triple pump noise level is given with each section discharging at the pressure noted on the curve.

HYDROMECHANICAL POWER LOSS (TYPICAL)

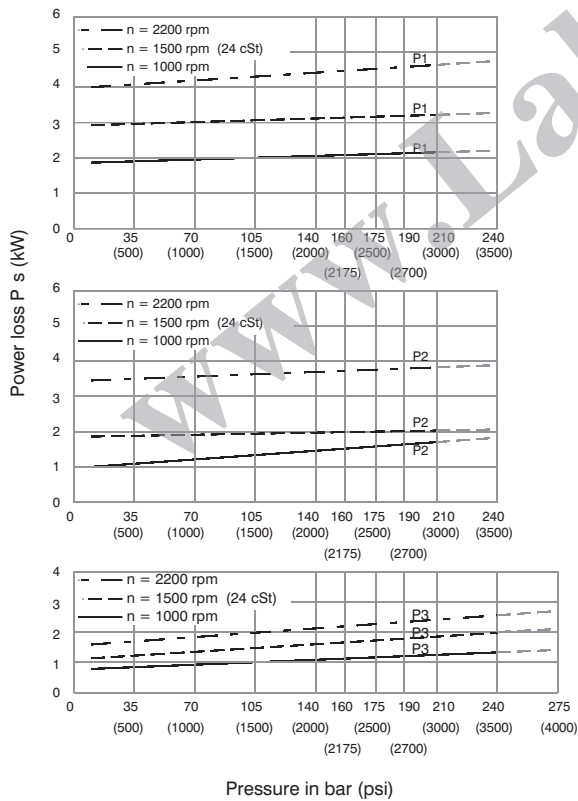

Total hydromechanical power loss is the sum of each section at its operating conditions

PERMISSIBLE RADIAL LOAD

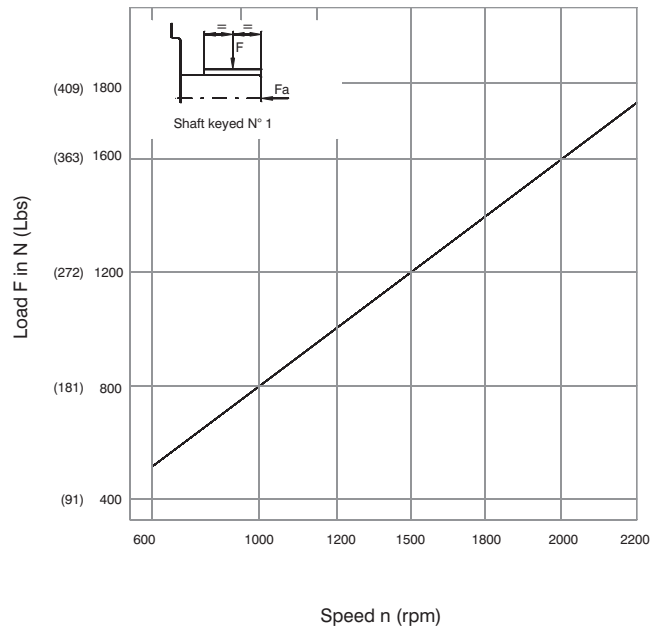

Maximum axial load permissible $F_a = 2000\text{N} (449 \text{ lbs})$



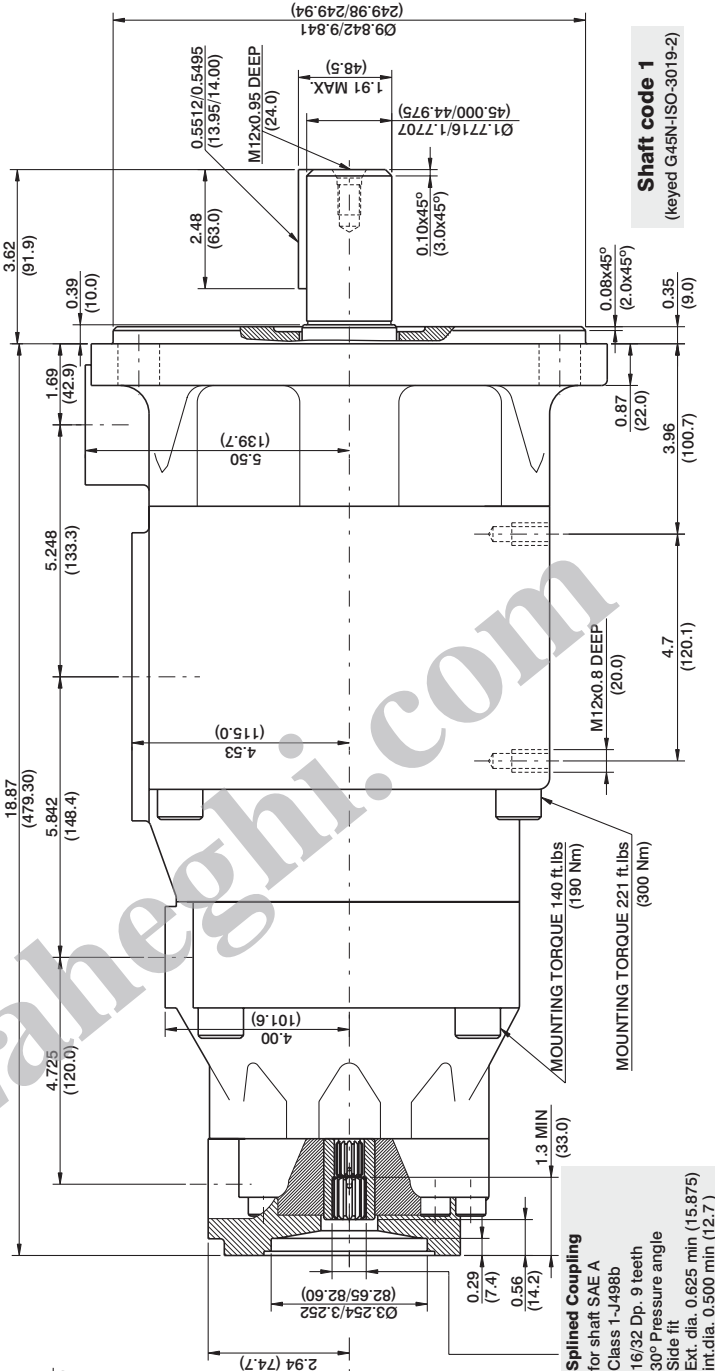
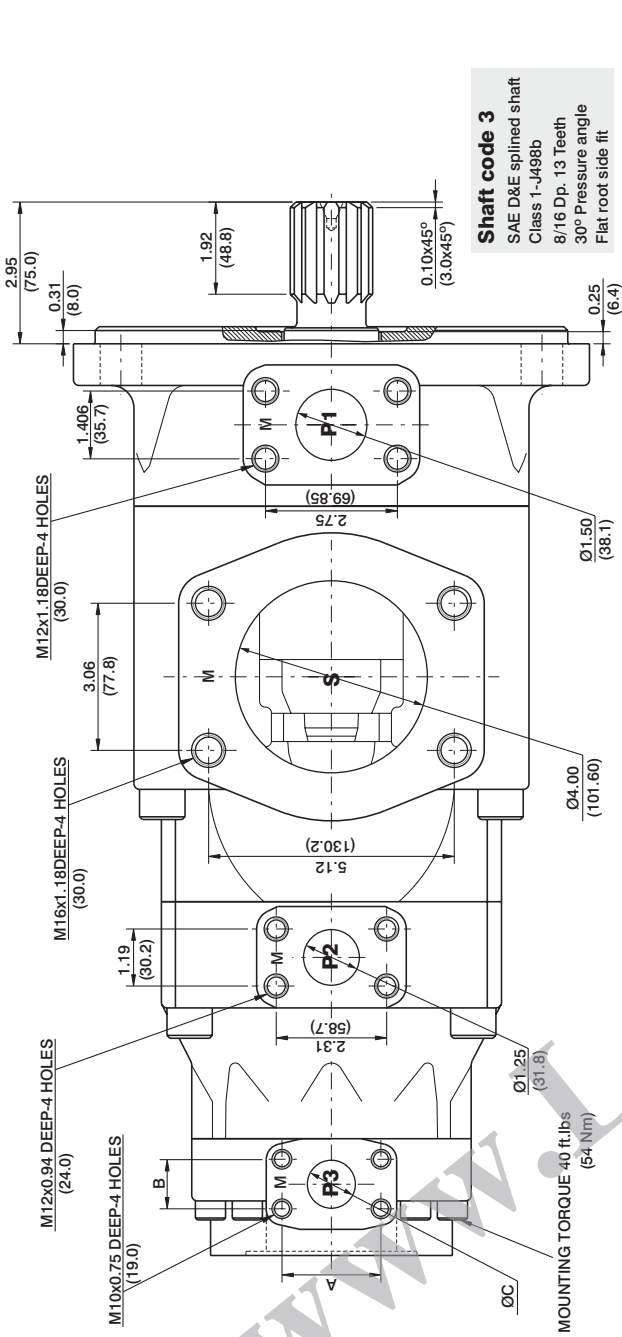

PORT CODE	A	B	C
P3	00	2.06 (52.4)	1.03 (26.2)
	01	1.874 (47.6)	0.874 (22.2)

Shaft torque limits in ³ /rev x psi (ml/rev x bar)
V x P max.
P1+P2+P3
Coupling drive
V x P max.
SAE'A'
3061 (3456)

